



## Pressalit Care Giraffe Changing Table Specifications

### Adjustable height, wall-mounted changing table.

- Lowers to less than 12" from the floor.
- Child/user climbs on themselves, minimal caregiver lifting.
- Raises to an ergonomic working height.
- Folds to save space.
- Completely accessible for cleaning and disinfecting.

#### Features:

Includes factory-installed safety rail.

#### Installation:

- Retrofit friendly.
- Anchors to wood blocking, masonry or concrete.
- Mounting hardware included.

#### Dimensions:

Available table lengths:

Small: 35.5" SKU/Model: R8971000/RB1922

Child: 55" SKU/Model: R8972000/RB1922

Width: 31.5"

Height adjust from 11.75" to 39.25"

Projection from wall: 35.5"

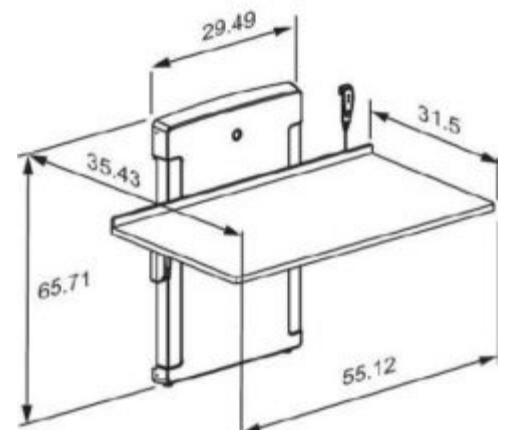

Pressalit Giraffe Child Dimensions

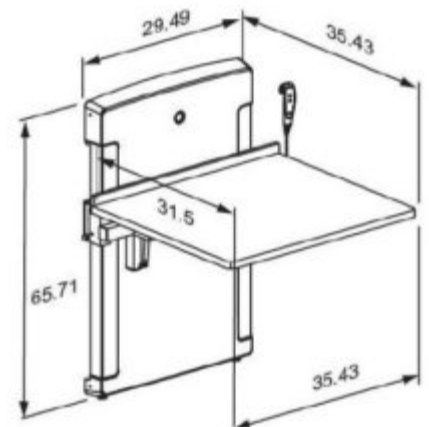

Pressalit Giraffe Small Size Dimensions

**Construction:** Lifting unit: Powder-lacquered steel.  
Worktop: ABS with acrylic.  
Integrated gas cylinder folding mechanism.

**Electrical:** Integrated transformer and US 8' power cord included.  
Linak liquid tight actuator and control system.  
Maintenance free motor.  
Built-in transformer.  
24v/1amp via 120 GFI wall outlet  
110 Volt and 3,9 Amp gives 390 Watts  
Effect( P ) = Volt (U) x Ampere (I)  
390 VA (Watt) = 110 V X 3,9 A  
390 Watt which is the maximum effect; power consumption is approximately 0 when not in use.  
Noise level: 48 decibels  
  
UL approved electrics

**Safety Rail:** Folds up or down.  
Easy one-handed operation.  
Locks securely in both positions.  
May be added to existing installations. (Contact our Sales Office to purchase separately.)

**Optional Mattress:** Thick, soft foam for user comfort.  
Fits small, child sized tables.  
Width: 30" Color: White  
Quality polyurethane, phtalate-free.  
Can be disinfected with antiseptic wipes.

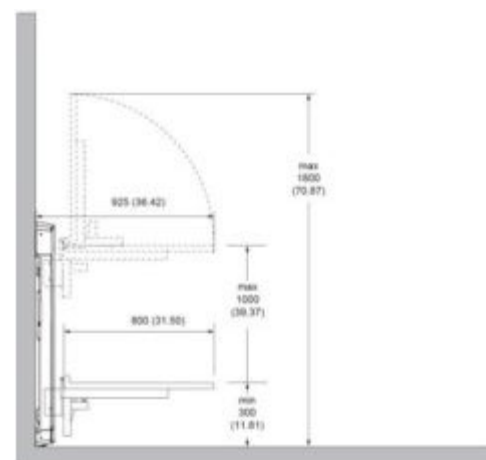

Pressalit Giraffe Dimensions -- Side View

### [Installation Drawing](#)

### [Wall Reinforcement Drawing](#)

Use a licensed contractor or plumber to install the product to avoid personal injury or property damage.

### [User Manual](#)

### Downloadable CAD Drawings:

- [CAD Drawing for Giraffe Daycare Changing Station — Child Size](#)
- [CAD Drawing for Giraffe Daycare Changing Station — Small Size](#)

Submital Info  
Spec Sheet  
(pdf)

(Contact our Sales Office to purchase separately.)

SKU: Small: R8701000; Child: R8702000

**Weight Capacity:** 165 lbs

**Product Weight:** 121 lbs (Small: 35.5" SKU/Model: R8971000/RB1922)  
132 lbs (Child: 55" SKU/Model: R8972000/RB1922)

**Availability:** Sold throughout the United States.

**Delivery:** Contact our Sales Office for up-to-date information.

**Discount:** Product price and shipping discount when purchasing multiple units. Call for details.  
800.577.1555

**Warranty:** Five years limited warranty on parts; one year on labor.  
[See our complete warranty and other policies here.](#)

Subject to change. Last updated May 2023.

## Access Your World

---

**MAX-Ability** offers complete restroom solutions that provide comfort, safety, and dignity to wheelchair users and caregivers, including ergonomic adjustable changing tables, sinks, toilets, and shower seats for total accommodation for everyone. Call us today and access your world!

**1.800.577.1555**



## Customer Service

---

[Purchasing & Payment Methods](#)

---

[Delivery / Returns / Warranty](#)

---

[Privacy Policy](#)

---

[Terms and Conditions](#)

## Resources

---

[Product Manuals](#)

---

[Installation Drawings](#)

---

[Internet Resources](#)

---

[Architects Resources \(inc. Specs/CAD\)](#)

## Connect with us

---



All rights reserved. Copyright 2023 © **MAX-Ability, Inc.**

MAX-Ability provides special needs equipment to consumers and businesses in the USA and Canada